

A large, stylized white letter 'W' is centered in the upper half of the image. The 'W' is composed of thick, rounded strokes and is set within a white square frame that has a slight 3D effect with a dark blue shadow. The background is a solid bright blue.

# WIRED

*Issue 13 - JULY 10*

***EURO CAR PARTS PRODUCT NEWS***



“Life’s too short to drive boring cars”



Brake Clinic



Profiling Point



Workshop Solutions



Collision Corner



New to range



Tips for Sourcing Tools



AirCon Station



Supplier Focus



Guess the Car

# Brake Clinic

## To Textar or not to Textar?



**E**veryone should know about TMD Friction, they are an OE manufacturer of brake friction who own both the Textar and Pagid brands. Following on from the recent articles regarding Textar, there is the possibility that you will be challenged about Textar being sent in place of Pagid.

Please remember the following about Textar:

- Textar and Pagid are both OE brands from TMD Friction and manufactured in the same facilities.
- If your customer receives Textar in place of Pagid, they are getting an equivalent product.

Textar is not an inferior product, and Textar pads are compatible with Pagid Discs



and vice versa. If you are challenged on this, don't lose the sale by trying to send out another set! Explain to your customer the compatibility and the manufacturer links with both brands. So to answer the question above – yes Textar!

If you are unsure, then please contact the PM team:

Aaron Spencer:  
[aaron.spencer@eurocarparts.com](mailto:aaron.spencer@eurocarparts.com)

Ehsan Arabalizadeh:  
[ehsan@eurocarparts.com](mailto:ehsan@eurocarparts.com)

# Workshop Solutions

## Brain Bee Diagnostic Software



### BRAIN BEE SOFTWARE TO INCLUDE TECHNICAL INFORMATION AND GUIDED DIAGNOSTICS AS STANDARD

NOW is a very good time for Brain Bee Diagnostics customers to renew expired subscriptions. Not only will they be able to download all the normal diagnostic updates they have been missing, but they will get a whole new very powerful capability called BPS - BRAIN PROBLEM SOLVER, developed in collaboration with HAYNESPRO, the technical information database!

Customers with active subscriptions simply have to connect their Brain Bee to their Laptop/PC to update their machine and the new Technical Information database will also download.

The addition of the Technical Information database is a great reason to persuade customers

with a lapsed subscription to renew their subscription (£595.00 + VAT)

The database includes:

**Maintenance** e.g. Oil grade & capacity

**Engine** e.g. timing belt replacement information

**Transmission** e.g. component location

**Steering Wheel, Suspensions, Brakes** e.g. alignment data

**Interior/Exterior** e.g. airbag arming and disarming procedures

**Electronics** e.g. wiring diagrams

Great as that is, the benefit of the Technical Information database is not simply the additional information made available to the technician right where they need it; the most significant benefit is the 'guided diagnostics' function (known as BPS Tutor)

which will take a technician step-by-step through the stages of any particular diagnostic procedure. This means that a technician is never 'stumbling through the dark' even on an unfamiliar vehicle system. The technician always has at his fingertips the background information and the step-by-step procedure of an expert.

This 'added-value' feature is either chargeable or not available at all on most other diagnostic software!

For more information on Brain Bee diagnostics please contact Fred Muraya or the Workshop Solutions team:

[fred.muraya@eurocarparts.com](mailto:fred.muraya@eurocarparts.com)  
Cisco: 7001 – 592

# New to range!

## Repair Flex BMW E60 5 Series



**H**as your customer ever had the issue where they needed to replace the whole DPF/Cat Converter because of one defunct part?

We are pleased to announce the introduction of the repair flex for BMW 520D E60 04 - with Close Coupled Cat/DPF.

The part 706 11 0021, comes with clamps for easy fitting. This product is perfect for cutting costs and offers the customer an option of replacing just the Flexi rather than the complete Cat/DPF, which as we all know can be extremely costly.

Dimensions are as follows - Total length 240mm, Inlet pipe 55mm external, Outlet pipe 65mm external.

Any queries, please don't hesitate to contact Paul Reynolds:

P: 02476 608192  
Cisco: 7044192  
M: 07747 765571



# AirCon Station

## Compressor Guards: Protect Your Neck

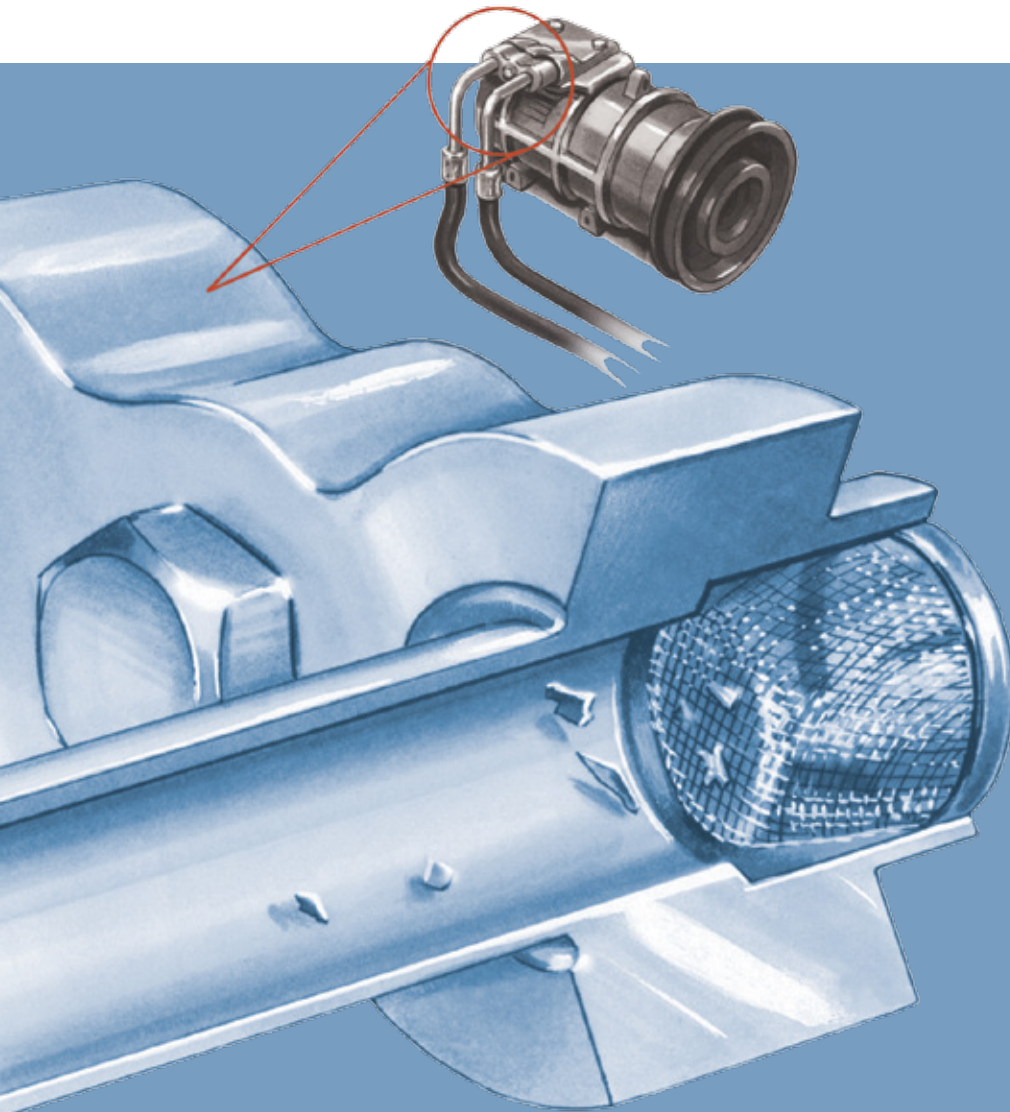

Imagine this, you've got an Air Con Machine which needs servicing, it works perfectly for a few months and then it packs up again, why? Compressor Guards. These vital little guardians protect you and your machine's warranty by stopping any debris from entering the compressor.

Debris in the suction line is a major reason replacement compressors come back "defective" more often than OE compressors. In the field, compressors go into a system that may be compromised by debris left over from the failure of the previous component.

AirSept's award-winning compressor guard suction screens trap metal shavings and other large debris. The new compressor guard ultimate suction screen kit

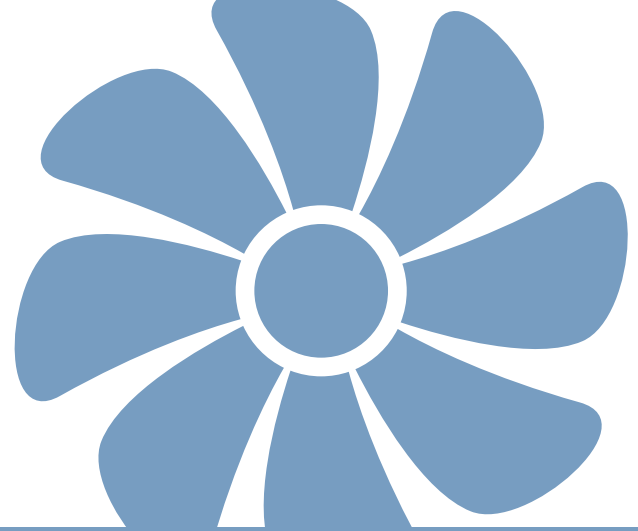

<b>Screen 0.538 - 13.67mm</b>	<b>264 77 1000</b>
<b>Screen 0.510 - 12.95mm</b>	<b>264 77 1010</b>
<b>Screen 0.595 - 15.11mm</b>	<b>264 77 1020</b>
<b>Screen 0.552 - 14.02mm</b>	<b>264 77 1030</b>
<b>Screen 0.531 - 13.49mm</b>	<b>264 77 1040</b>
<b>Screen 0.821 - 20.85mm</b>	<b>264 77 1050</b>
<b>Screen 0.618 - 15.70mm</b>	<b>264 77 1060</b>
<b>Screen 0.649 - 16.50mm</b>	<b>264 77 1070</b>
<b>Screen 0.471 - 11.96mm</b>	<b>264 77 1080</b>
<b>Screen 0.521 - 13.23mm</b>	<b>264 77 1090</b>

contains 12 new screen sizes, for a total of 20 different sizes. The new screen sizes expand coverage to almost any vehicle on the road today, including many low volume and odd size compressor hose assemblies. The new compressor guard ultimate suction screen kit is

likely to have a screen that fits. When a compressor fails in use, debris particles flow in both directions. Although most debris travels down the high side, some does flow upstream from the compressor suction port towards the suction muffler, hose,

accumulator or receiver/drier and evaporator. Even flushing cannot guarantee 100% removal of these metallic Trojan Horses. OE-approved compressor guard screens install in the suction port on the hose assembly. They trap any large debris heading toward the replacement compressor. Installation takes less than five minutes with no hose cutting. Particles that are too small to harm the compressor pass through the screen, so there is no reduction of refrigerant and lubricant flow. Replacement screens are available in packs of five of any single size (Table).

As always, if you need any help our Air Con team is on hand to answer any questions:

Aaron McFarlane:  
[aaron.macfarlane@eurocarparts.com](mailto:aaron.macfarlane@eurocarparts.com)  
Cisco: 7001 - 595

# Supplier Focus

## BBT GmbH



## Automotive Components GmbH

**B**BT Automotive Components GmbH is one of the leading manufacturers of ignition coils and ignition lead sets especially for the German and European market. Apart from their made in Germany manufactured ignition products, produced for the automotive aftermarket near their capital Berlin, they also offer a comprehensive program of sensors, oxygen sensors, camshaft and crankshaft sensors, and mass air flow sensors. BBT is a well-established brand with over two decades of manufacturing and development history. BBT

focus on quality and reliability, whilst remaining competitively priced in the automotive aftermarket.

BBT is fully committed to providing customers with an excellent expert service and detailed information about all their products. Product quality is a priority, along with competitive prices. All products offered are engineered with German technology and tested with our expertise in BBT's laboratories.

### MAIN CUSTOMERS

BBT produce ignition products to the following customers

Bosch, Beru, Euro Car Parts, Hella, Ferdinand Bilstein and many more.

### BBT QUALITY CONTROL, RESEARCH AND DEVELOPMENT

BBT performs quality control for production and standard sales item by applying strict ISO requirements, based on the six sigma statistical analysis for failing parts. This means, BBT are not only looking to keep all of the correct tolerances within specifications, but in addition they are looking for drift and changes, which is exactly the same procedures that an OEM supplier would adopt.

If you have any question regarding BBT GmbH please contact Colin Downie:

[colin.downie@eurocarparts.com](mailto:colin.downie@eurocarparts.com)



# Profiling Point

## Castrol Gear Oils

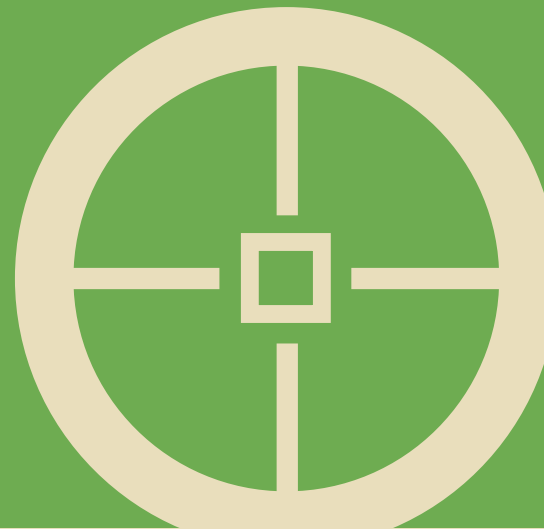

### **CASTROL SYNTRANS FE 75W 1LTR**

522 77 1612

Popular Ford Gear Oil profiled into the NDC, Wembley and Hubs. Castrol Syntrans FE 75W is a full synthetic transmission fluid recommended for most passenger car manual and “dry clutch” transmissions where API GL 4 lubricants are required. Castrol Syntrans FE 75W meets Ford standard WSS-M2C200-D2 and is much in demand among Ford owners.

This transmission oil is popular because of the smoother gear shifts it provides. The low viscosity formulation can lead to improvements in fuel economy and the synthetic formula extends gearbox life. Castrol Syntrans FE works extremely well from cold while still offering excellent shear stability and longevity when hot. Castrol Syntrans FE 75W is ideal for:



Ford Focus, C-Max, Mondeo, S-Max, Galaxy, Transit, Volvo C30, S40, V50, S60, V70, C70, XC60, and XC70.

### **SPECIFICATION**

API GL-4  
Ford WSS-M2C200-D2

### **CASTROL SYNTRANS MULTIVEHICLE 75W-90 1LTR**

522 77 1222

Popular Multivehicle Gear Oil profiled to most branches. A fully synthetic SAE 75W-90 manual transmission fluid recommended for most manual

transmissions where API GL-4 lubricants are required. It has been successfully used as a problem solver for low temperature shiftability issues in the manual transmissions of a number of manufacturers. Application is for most cars requiring API GL-4 and superior low temperature shiftability, especially suitable for Ford, Honda and Vauxhall models.

### **SPECIFICATION**

API GL-4  
Ford WSD-M2C200-C  
MB-Approval 235.72

To Download MSDS sheets and TDS please click on this attached link  
[http://www.castrol.com/en\\_gb/united-kingdom/products/cars/manual-transmission-fluids.html](http://www.castrol.com/en_gb/united-kingdom/products/cars/manual-transmission-fluids.html)

If you need this to be added to your branch profile please email [pankaj.babbar@eurocarparts.com](mailto:pankaj.babbar@eurocarparts.com)

# Collision Corner

## S-TEC OE Mirrors at Aftermarket prices

**S**-TEC are the aftermarket arm of the Magna group – the 5th largest manufacturer of all OE parts in the world.

We currently stock their range of OE mirrors and mirrors parts; and this includes Audi, BMW, Ford, Iveco, Land Rover, Mercedes, VW and many more. We have a huge range in stock of these Mirror Housings, Glasses, Covers, Indicators, Motors and other components. They are supplied just as the Dealer parts are, so if a BMW dealer mirror is supplied separately as a housing, a glass, a cover, indicator, kerb lamp and trim so are our S-TEC mirrors.

They ARE the BMW mirrors and parts, just with the BMW logo scratched off them when they are taken off the BMW production line; and we can pass on big cost savings to the customer!



They are exclusively supplied to ECP in aftermarket, in many cases with no Aftermarket alternative!

So the customer can buy these from the dealer, or from you, that is their only choice. You do not

need to reduce the prices; we are very competitive against the dealer.

The range includes Electro Chromatic / 'Auto-Dimming' mirror glasses; these are such high-technology that the aftermarket manufacturers cannot yet manufacture them. Once again, so the customer can buy these from the dealer, or from you, that is their only choice. You do not need to reduce the prices; we are very competitive against the dealer. As always, contact our Collision

Product Managers for more information or help in sourcing that perfect part:

**Chris Graham** – Bodyparts  
Cisco 7001-191

**Chris Curtis** – Lighting  
Cisco 7955-021

**Gareth Rhodes** – Mirrors, PDCs, Dampers, Window Regulators  
Cisco 7955-022

# Tips for Sourcing Tools

## **ABAC**

*www.abacaircompressors.com/ukus*  
01869 326 226

## **Alba Diagnostics Ltd**

*www.albadiagnostics.com*  
01592 774 333

## **AST Tools**

*www.asttools.co.uk*  
01527 528 848

## **Autel**

*www.autel-tech.com*  
0333 0129 959

## **Compac**

*compac.dk*

## **Dun Bri**

*www.dun-bri.com*  
01763 274 185

## **Fast Mover Tools**

*www.fastmovertoolsuk.com*  
01582 661 993

## **Haztec**

*www.haztec.uk*  
0113 202 9115

## **Karcher**

*www.karcher.co.uk/uk/Home.htm*  
01295 752 000

**IF YOU KNOW WHICH BRAND OF TOOL YOU ARE LOOKING FOR YOU CAN USE ANY OF THE SUPPLIERS WEBSITES LISTED BELOW. PLEASE FAMILIARISE YOURSELF WITH THEM AS THEY ARE EASY TO USE AND WILL NO DOUBT HELP YOU INCREASE YOUR SALES.**

**FOR TIMING TOOLS USE LASER, THEIR LOOK UP IS CLEAR, CONCISE AND ACCURATE. THIS APPLIES TO SEARCHES AFTER YOU HAVE TRIED TOPCAT AS WE NOW HAVE THE TOP 50 LASER TIMING TOOLS LINKED TO THE INA TIMING KITS.**

**THE LINKS BELOW WILL COVER THE MAJORITY OF THE INQUIRIES THAT YOU WILL RECEIVE, FROM YOUR CUSTOMERS.**

## **Klann Tools**

*www.klanntools.co.uk*  
01756 706 700

## **Laser**

*www.lasertools.co.uk*  
01926 815 000

## **Milwaukee**

*uk.milwaukeeeetool.eu*  
01628 894 400

## **Norbar**

*www.norbar.com*  
01295 753 600

## **Omega**

*www.omegatools.co.uk*  
01539 739 733

## **Pagid**

*www.pagidprofessional.co.uk/materials/pagid-tools-catalogue*

**Sealey B2B** website, give OUR price and their stock availability

*b2b.sealey.co.uk*

Log in: "ecp" and password is "eurocarparts"  
This website will give you the option to word search by using the horizontal blue bar across the top or the index sections on the left vertical column.

01284 757 500 – Sales  
01284 757 505 - Technical

## **SIP Tools**

*www.sip-group.com*  
01509 500 500

## **Sykes**

*www.sykes-pickavant.com*  
01543 679 900

If you are unable to find the tool that you need, then and only then you should contact the webchat team.

If you need a part number created please email [prodman@eurocarparts.com](mailto:prodman@eurocarparts.com) and we will assist you as long as you can help with the following:

- Brand
- Supplier
- Cost
- Description
- Sell out (this may require Head Office to dictate/correct).

Please also remember than inquiries for availability should be made through Special Orders Team.

# Guess the car ...



This week we want you to guess the blacked out car!  
The clue is that it's a car that's mentioned inside  
this issue of Wired!

If you think you know what car this is,  
please email the **MAKE AND MODEL** to  
[jasmeeet.marway@eurocarparts.com](mailto:jasmeeet.marway@eurocarparts.com)

3 lucky winners, picked at random,  
will win an Air Canon! Blast Away!

